

Ionization Energy Losses of Low-Energy Alpha Particles in Methylal

V.H. Khachatryan

A.I. Alikhanian National Science Laboratory (AANL)

Received 19 March 2019

Abstract. The energy losses of alpha particles have been measured in Methylal gas and compared with the Stopping and Range of Ions in Matter SRIM-2008. The alpha particle energy losses have been experimentally determined for ^{239}Pu α -particle source using a dedicated experimental setup based on low-pressure multi-wire proportional chambers (LPMWPC); such losses are observed to deviate significantly from the calculated ones. The deviations suggested that in the low (≤ 1 MeV) energy region the stopping powers given by SRIM-2013 might be too high of about 5-10%.

Keywords: Stopping power, energy loss, alpha particles, LPMWPC technique

1. Introduction

Stopping of charged particles and ions in the matter has been a subject which has received great theoretical and experimental interest; the phenomena are usually characterized by the stopping powers. Stopping powers have been reviewed in many journals (see e.g. [1-6]). Stopping and Range of Ions in Matter (SRIM-2013) [7] software acquires the most updated dataset of stopping powers in different media. In the present work, we compare the alpha-particle energy losses in Methylal obtained from experiments and from stopping powers given SRIM-2013. The alpha particle energy losses have been experimentally determined for ^{239}Pu source using alpha spectroscopy; such losses are observed to deviate significantly from the calculated ones. The deviations suggested that the stopping powers given by SRIM-2013 might be too high especially in the energy region less than 1MeV , which is also suggested other works as well for air [11]. In the present work, we propose a new method to verify these stopping powers. In this method, the alpha-particle energy losses in Methylal are measured directly by using a dedicated experimental setup based on Low-Pressure Multi-Wire Proportional Chambers (LPMWPCs) [9,10,11].

2. Experimental setup

An experimental setup based on the LPMWPCs was developed in order to investigate ionization energy losses of low-energy alpha particles in Methylal. The alpha source employed in the present study was a planar, $0.14\text{mg}/\text{cm}^2$ thick, $30\times 30\text{mm}^2$ ^{239}Pu source. This has three lines: 11%–5.099, 20%–5.137 and 69%–5.150MeV. The geometry of the setup is shown in FIG. 1. It consists of two MWPC1 and MWPC2 units, mounted at 5.5cm distance from each other detected the α -particles, which were collimated by 7mm holes bored in $100\mu\text{m}$ Mylar ($\text{C}_{10}\text{H}_8\text{O}_4$) absorbers.

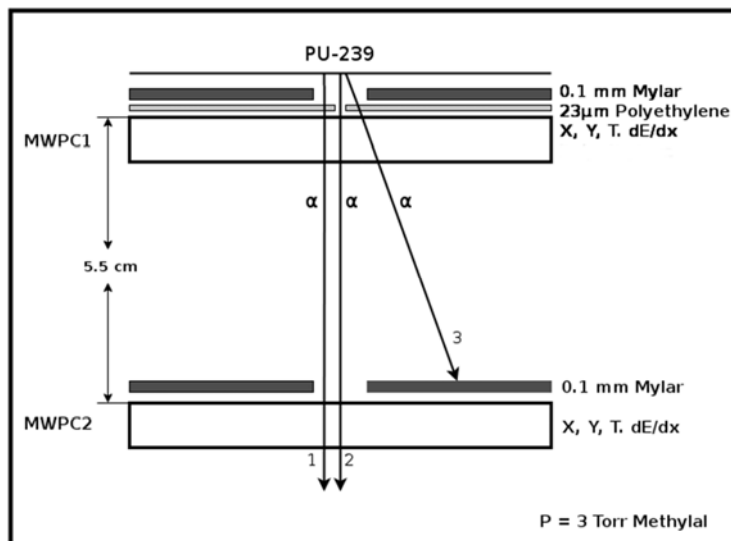

Figure 1. The schematic view of the experimental setup. 1- alphas that pass through 23 μ m Polyethylene and 5.5cm 3Torr Methylal, 2 - alphas that pass through Methylal, 3 - alphas that are absorbed.

The structure and operational mode of LPMWPCs are described in [14], it is a multi-wire proportional chamber with the active area of $3 \times 3 \text{ cm}^2$. The time of flight (TOF) and dE/dx distributions from the MWPCs were recorded. In these studies, data was also obtained for reduced α -particle energies, by placing a polyethylene moderator between the first Mylar collimator and the MWPC1. In this case, the holes in the Mylar collimators had 7mm diameter and the polyethylene (C_2H_4)_n absorber had a 3mm hole, which allowed simultaneous detection of incident α -particles and α -particles after passing through the polyethylene moderator.

3. The electronics and logic of signal extraction and processing

The analog signals from anode1 (A1) and anode2 (A2) of the MWPC1 and MWPC2 modules were registered with Picoscope 6407 series, with 5GS/s and 1GHz analog bandwidth. As the Picoscope voltage range is 100mv the amplified signals which reach about 500V were attenuated with 15 and 10dB for A2 and A1 channels respectively. The trigger was formed with the A2 signal and signals with the minimum amplitude of less than -5mV were registered (Fig. 2). The connection between Picoscope and the Labview was performed with the help of Picoscope GitHub examples [15]. A Labview program was written to register signal pairs event by event as a waveform and save the data as a CSV file.

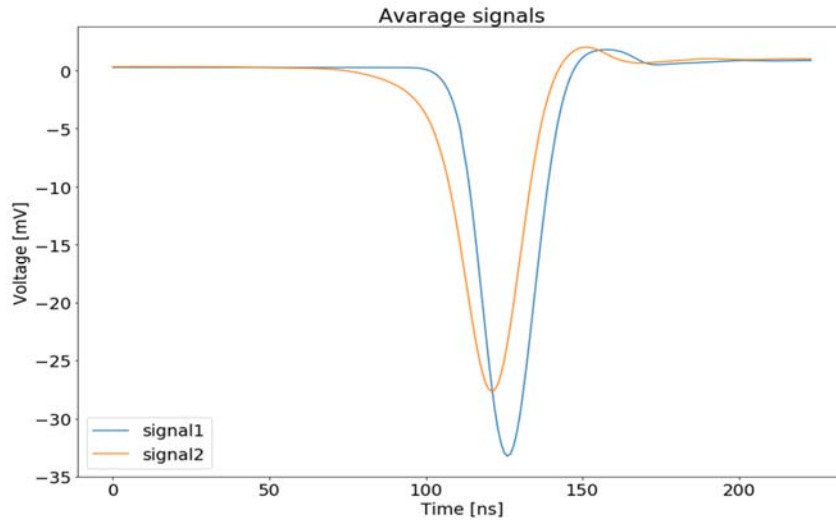

Figure 2. The average signals from the anodes: signal1 and signal2 are from A2 and A1, respectively.

The detector signals were mostly good signals, but to be sure that bad signals or noises are eliminated and they can't affect to the distribution of the TOF and the signal amplitude a subtle method was applied. As we know from the shape of the signals, a perfect signal should be like Gaussian function, and the alternation from the function means that it is potentially a noise. Every signal pair were fitted with the Gaussian function and the chi-square was calculated with the help of Python software package and Gaussian Model from lmfit library (Fig. 3).

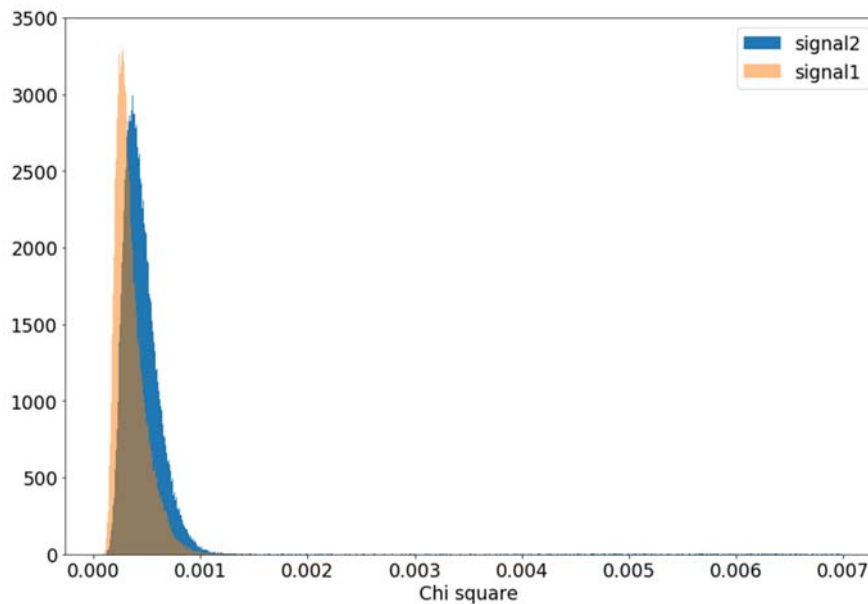

Figure 3. The distribution of Chi-square: signal2 is from A1 and signal1 from A2 signals.

The shape of the signals which has chi-square bigger than 0.001 were mostly bad signals or noise coming from either drastic changes of the voltage in the electrical network, or from other charged particles with less ionization energy. Thus the 0.001 threshold was applied and the only good signals were chosen to obtain maximum good resolution.

For digitization of the signal waveform (ADC- Analog to digital converter), the minimum of the fitted Gaussian peak was taken. The ADC of each signal corresponds to deposited energy of the alpha particles in the Methylal gas which is respectively relative to the energy of the alpha particle. So the distribution of ADC will show the overall deposited energy in the detector (Fig 4.). On another hand, the difference of the argmins of the ADC's for A1 and A2 signals will determine the TDC (Time to digital converter) which is the TOF of the alpha particles. From TOF we can simply get the velocity of alpha particles consequently composing the energy distribution.

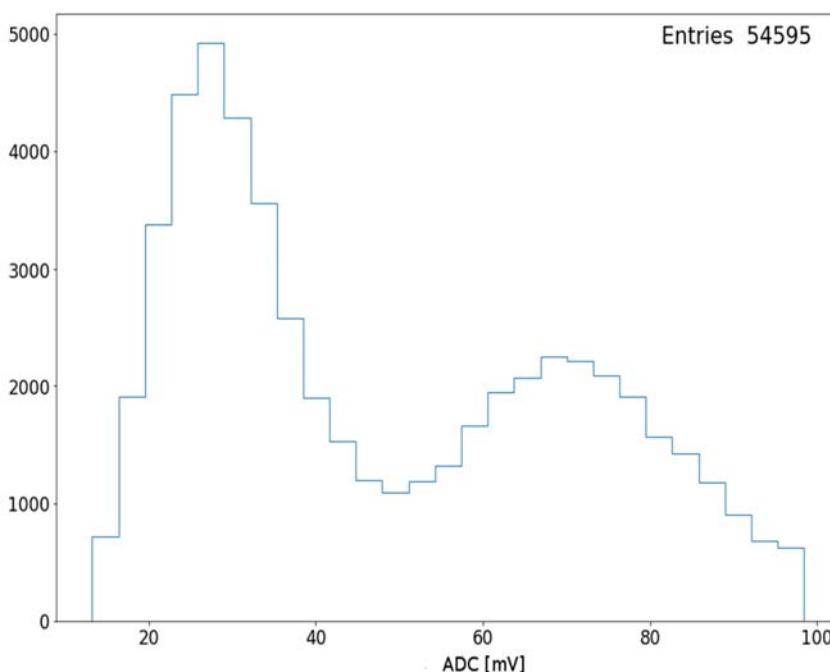

Figure 4. The ADC distribution of the A2 signal in mV.

We can observe two peaks in Fig. 5. The first one is the alpha particles that passed directly through the Methylal gas without interacting with polyethylene moderator, and the second peak is alphas after interacting with polyethylene. In order to calibrate the energy from the time information, the mean of the first peak has been adjusted to the 5.15MeV , which is the mean energy of alpha particles emitted from ^{239}Pu source.

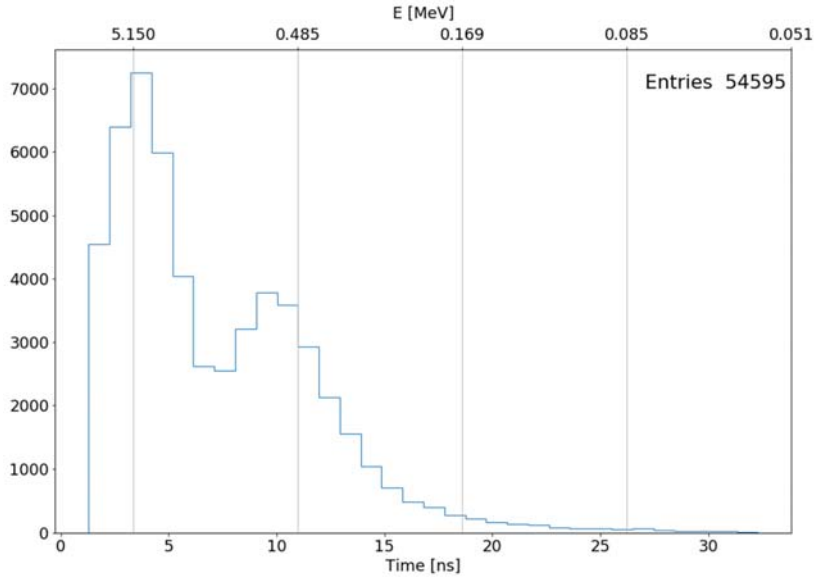

Figure 5. The TOF distribution of alpha particles. Lower axis shows the time of flight of alpha particles, and upper axis shows their corresponding energies.

The distribution of the TOF was divided into small chunks and for each chunk, ADC distribution was generated. The mean of the ADC distribution then was picked which is, in fact, the dE/dx for that given chunk of time (therefore Energy). The errors of the experimental points were determined as the σ/\sqrt{n} where the σ is the standard deviation and n is the number of events for each chunk, which turned out to be neglectable with respect of the absolute value of ADC. Consequently for every Energy the dE/dx was determined, nevertheless, it needs to be calibrated because the absolute value maximum of the peaks has no meaning. In the experimental data, the absolute value of the ADC corresponding to the 5.15MeV is 25(Fig. 6).

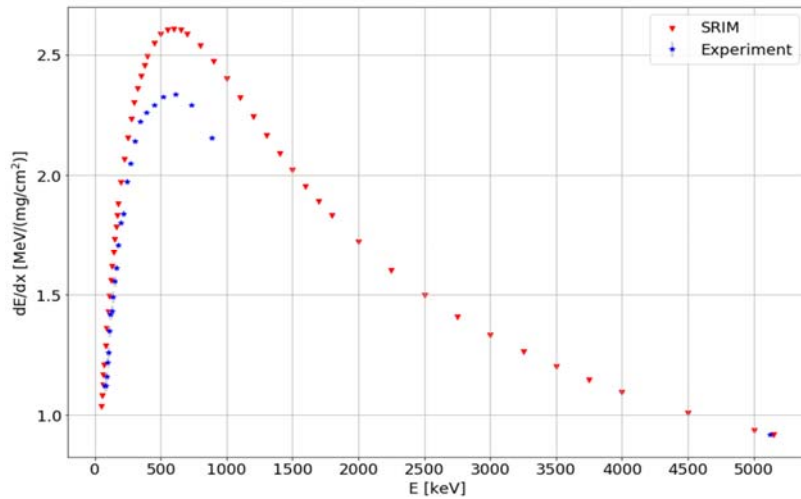

Figure 6. The energy loss of the alpha particles in methylal. Red-triangle is the SRIM data and the blue-star is the experimental data (In the experimental value of 5.15MeV that is colored in the blue star is a little bit shifted to be distinguishable from the red triangle)

To calibrate the ADC values this 25 value should be scaled to the 0.91 which is the corresponding energy loss of the alpha particles in methylal according to the SRIM software dataset [8] (we trust SRIM at this energies): see the red triangle in 5.15MeV in Fig 6. Henceforth, we transform each ADC values in the following way: $ADC * 0.91 / 25$ and obtain $MeV / (mg / cm^2)$ units. We then employed the stopping powers provided by the SRIM-2013, which calculated the stopping and range of ions ($10eV - 2GeV / amu$) into matter using a quantum mechanical treatment of ion-atom collisions (the manual of SRIM refers to the moving atom as an “ion”, and all target atoms as “atoms”). On the main menu of the SRIM-2013 software, the stopping and range table was selected. In this table, we selected “Helium” in the ion row and added $C_3H_8O_2$ to be the target with no Bragg correction. Finally, we clicked “Calculate Table” and a list of total stopping powers and estimates of the range for alpha particles in methylal was generated. The SRIM dataset results alongside with the empirical data are depicted in Fig.6.

The results of the experimental data show that the SRIM dataset in low energy regions has inaccuracy and shows about 5–10% more than those in the experiment. This means that alpha particles have higher ranges than it is estimated in SRIM dataset.

For later development and experiment precision we plan to do more measurement with different gases. Besides in the current experiment only A1 signals were used for ADC distribution, the A2 signals are slightly larger than A1 which we do not still understand and will try to explain in upcoming papers.

4. Conclusion

In conclusion, we have described the measurements of dE/dx of low energy α -particles in Methylal using a position sensitive LPMWPC system with active area $3 \times 3 cm^2$. A thorough measurement and analysis were performed using Picoscope data acquisition and python software to filter noise from the pure signal. The results show that if the energy loss of the alpha particles in SRIM-2013 dataset reduced by 10% they would agree satisfactorily with the experimental data.

Acknowledgments

The author would like to thank the members AANL 100/3 experimental group for their efforts during the measurements, Amur Margaryan for useful discussions, and Robert Ayvazyan for helping to construct the detector. This work is supported in part by the grant from the 16-A1c66 of State Committee of Science, Republic of Armenia and Ruben Vardanyan foundation.

References

- [1] S.P., Ahlen, 1980. Rev. Mod. Phys. 52 (1), 121–173.
- [2] I., Kaplan, Nuclear Physics. 1964.
- [3] S., Kinsman, US Government Printing Office, 1954.
- [4] U., Littmark, Ziegler, J.F., 1980. Pergamon, New York.

- [5] US Department of Health, Education, and Welfare, 1970.
- [6] J.F., Ziegler ,IBM-Research, 1985.
- [7] J.F., Ziegler, SRIM-2013. <http://www.srim.org/>
- [8] K. N.Yu et al., Applied Radiation and Isotopes 59 (2003) 363–366.
- [9] A. Breskin, et al., IEEE Trans. Nucl. Sci., 27, 133 (1980).
- [10] K. Assamagan, et al, Nucl. Instr. and Meth. A426, 405 (1999).
- [11] A. Margaryan, et al., Armenian Journal of Physics, 3(2010), 282.
- [12] R. Ajvazyan, et al., Particles, 1(2018), 126-137.
- [13] Pico Technology Ltd, 2014-2017, <https://github.com/picotech/picosdk-ps6000-matlab-instrument-driver>.